

Lavorazioni

「**terre** 450」

*Processing*



terre 450

Lavorazioni Processing

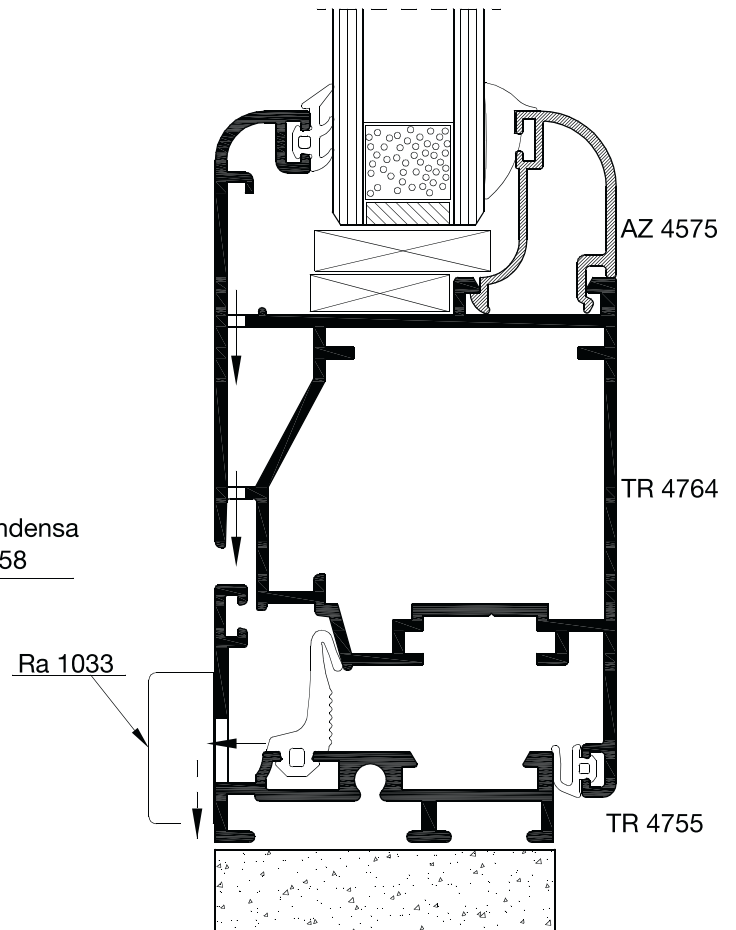
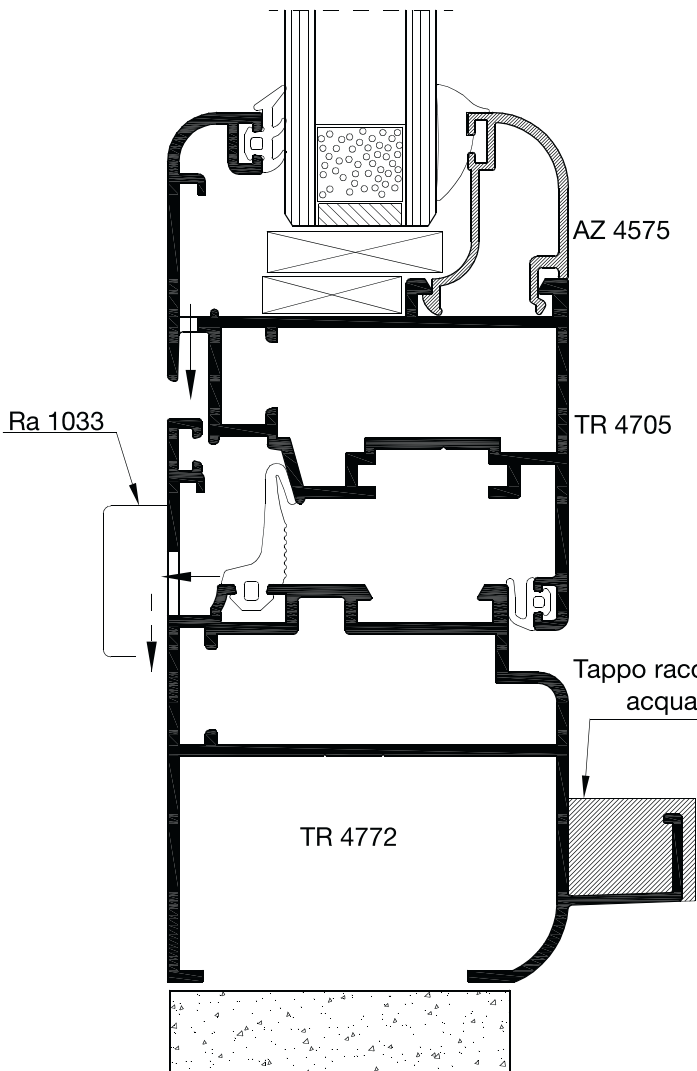
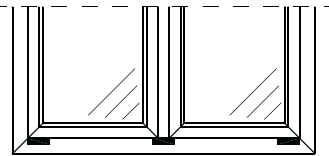
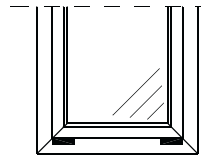
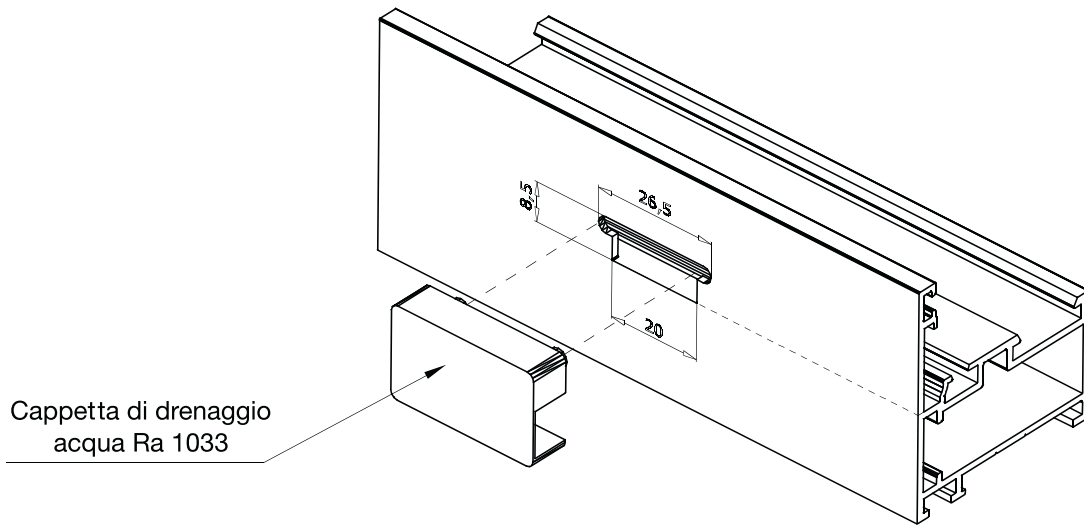

N.B. - Lavorazione eseguita con punzonatrice Ra 3800

Lavorazioni Processing

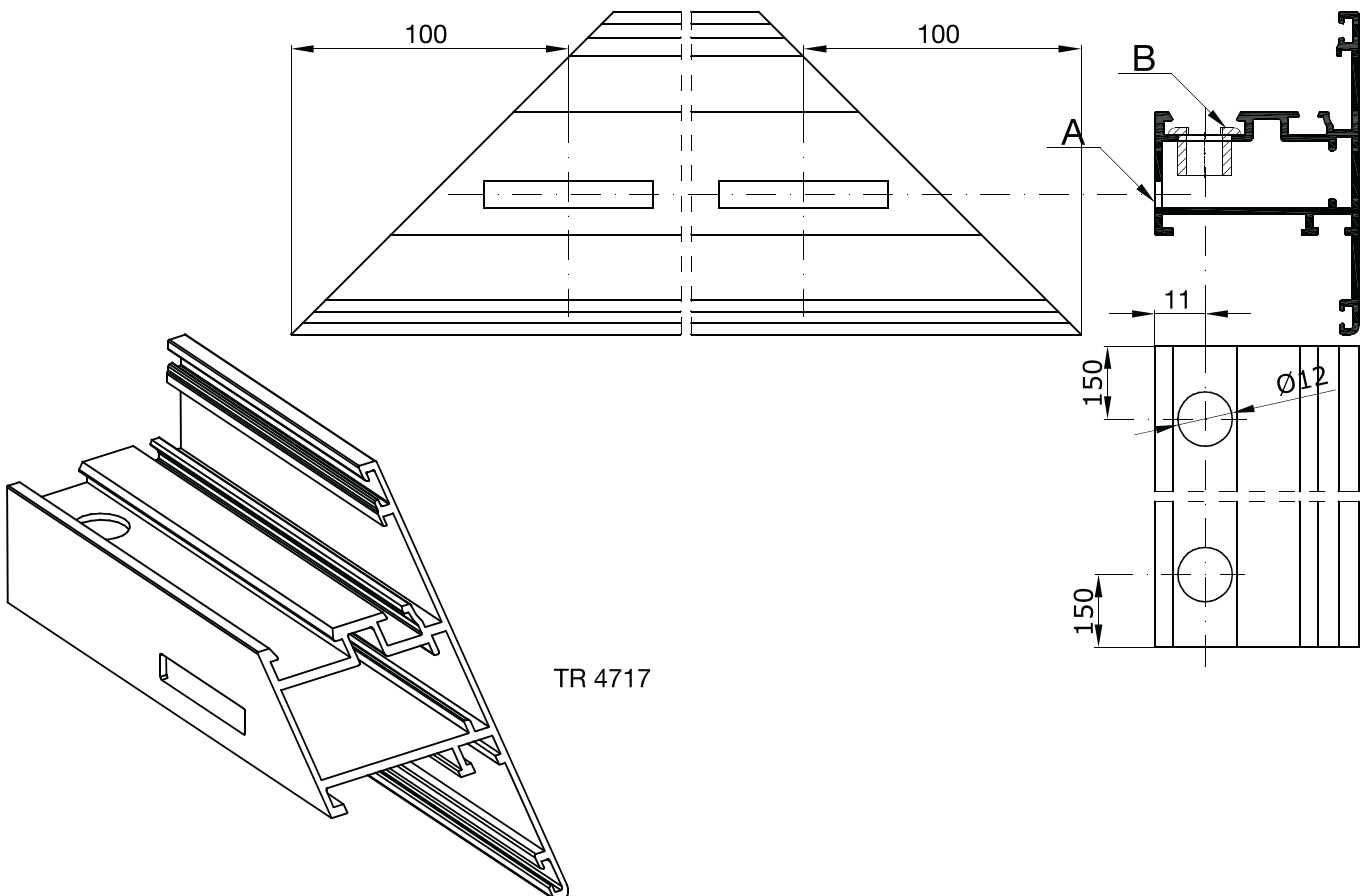
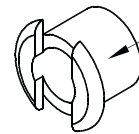
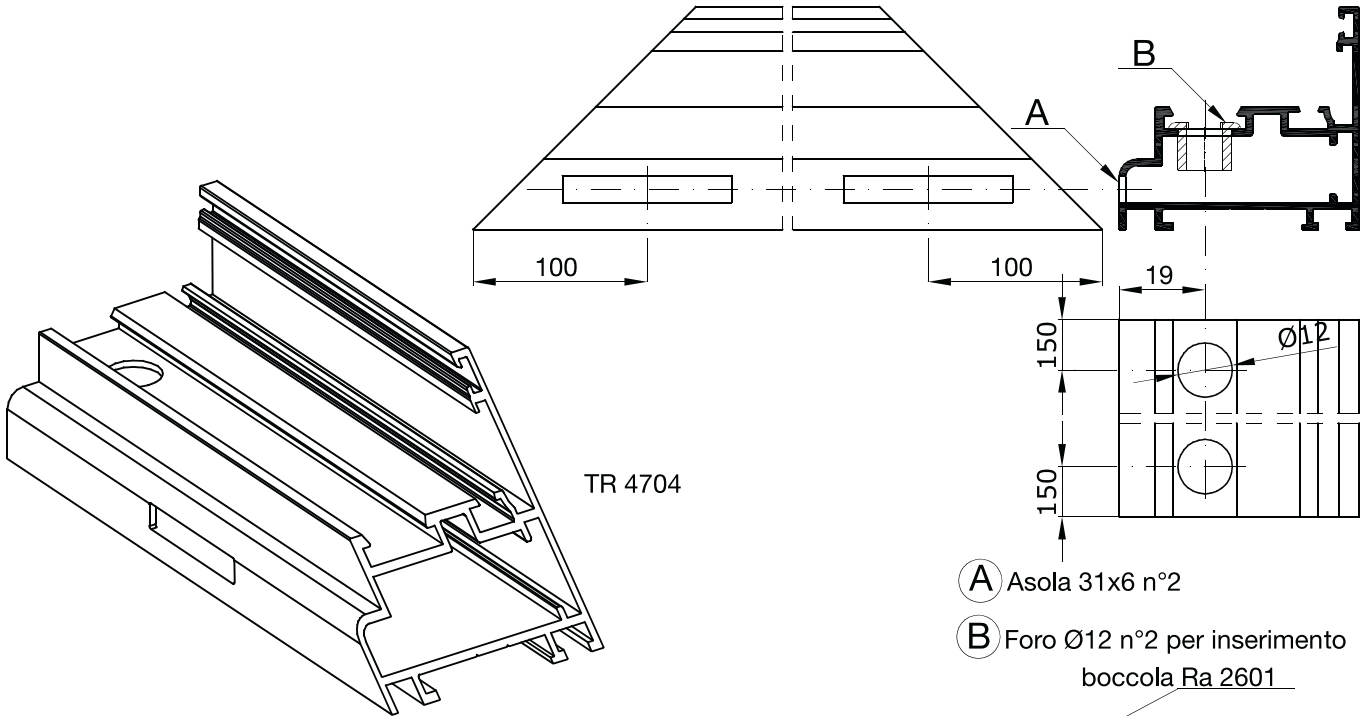

Lavorazioni Processing

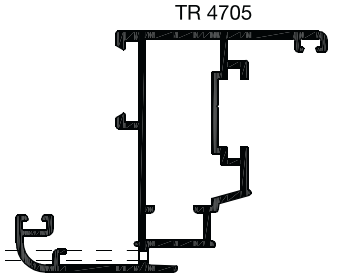
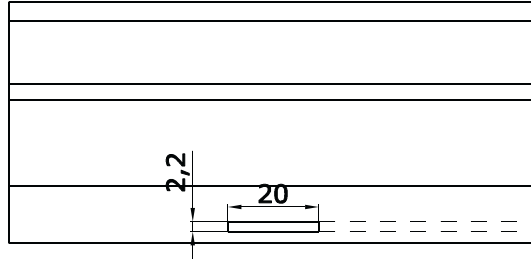
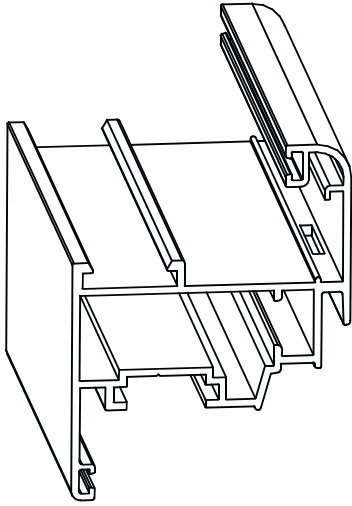

TR 4705

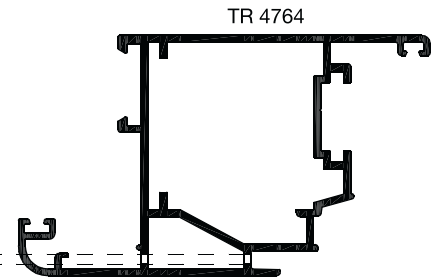
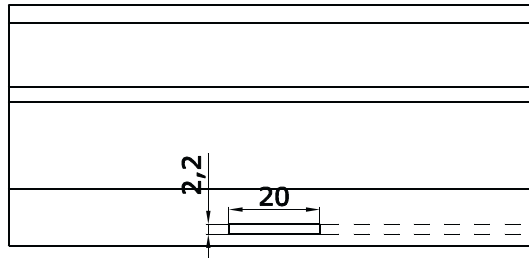
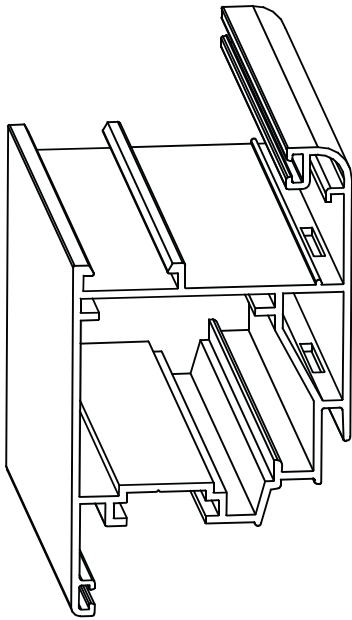

TR 4764

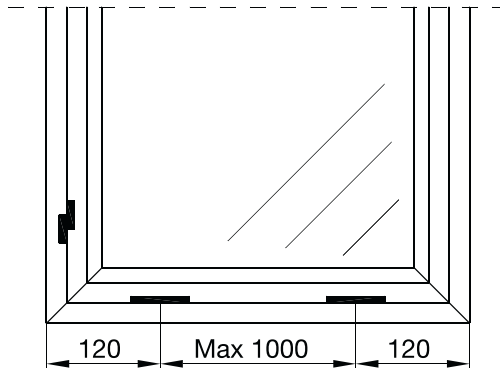

N.B. - Lavorazione eseguita con punzonatrice Ra 3800

Lavorazioni Processing

Squadretta a pulsante  
Ra 1406

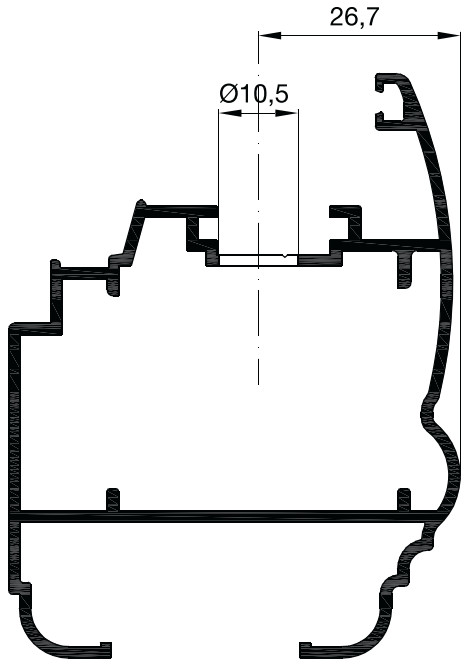

TR 4730

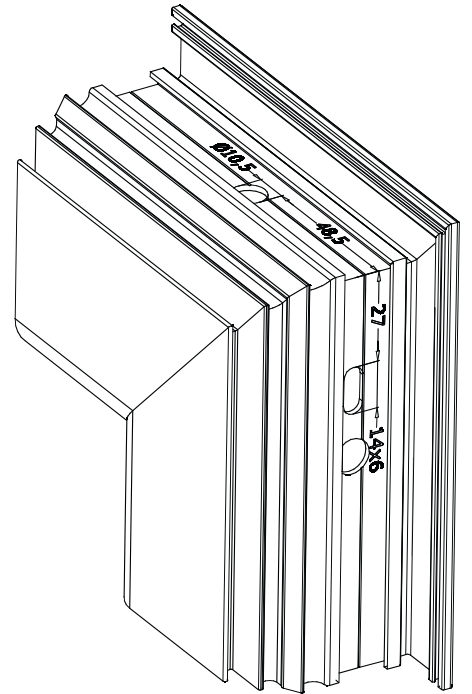

Squadretta a spinare  
Ra 1405

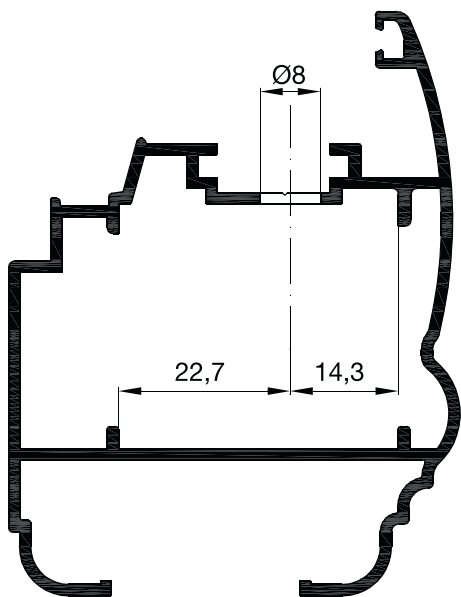

TR 4730

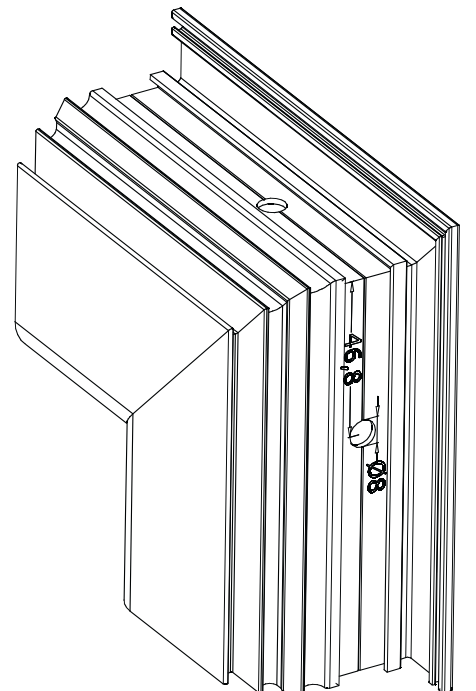

N.B. - Lavorazione eseguita con punzonatrice Ra 3800  
- Per l'unione degli angoli si consiglia l'utilizzo del collante

Lavorazioni Processing

Squadretta a pulsante  
Ra 1408

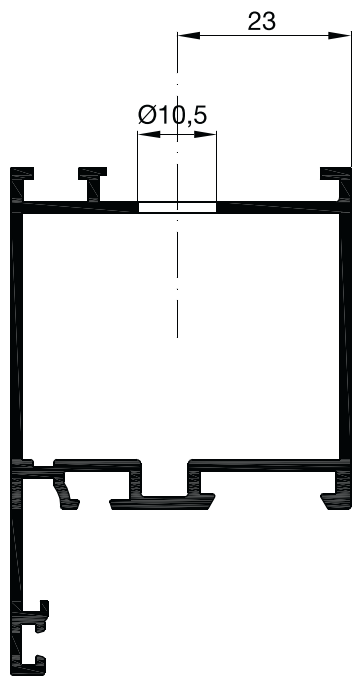

TR 4720

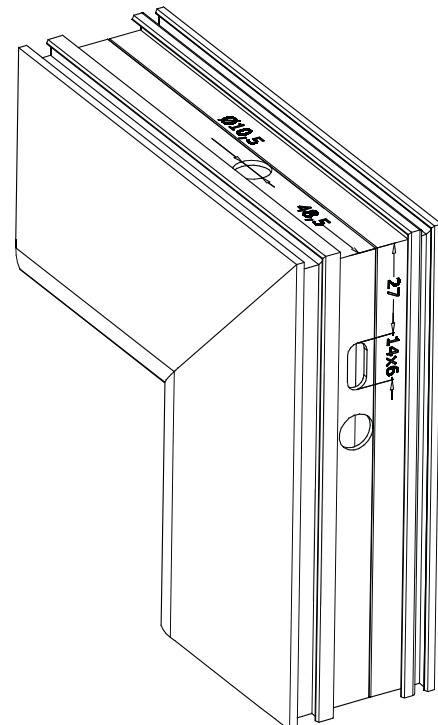

Squadretta a spinare  
Ra 1407

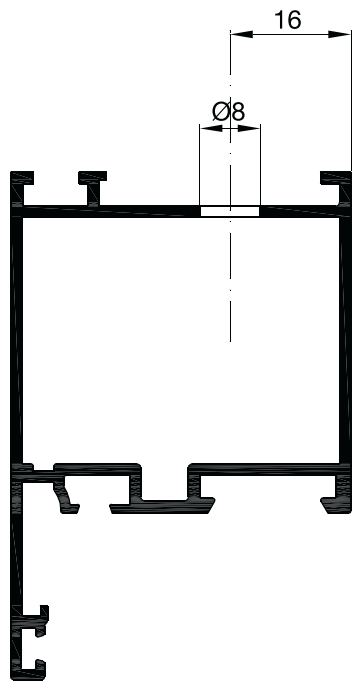

TR 4720

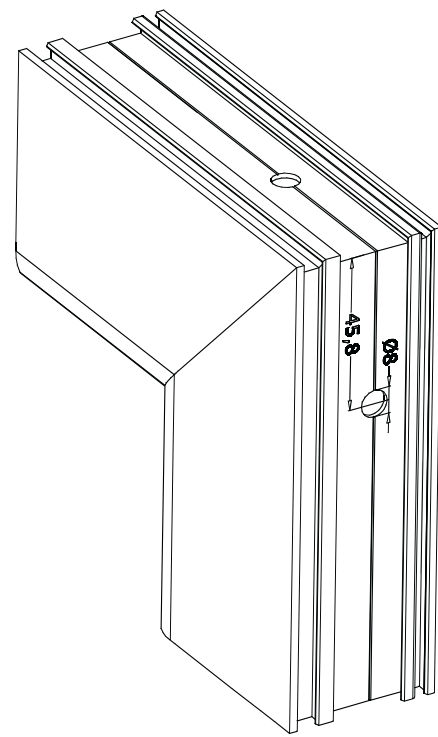

N.B. - Lavorazione eseguita con punzonatrice Ra 3800

- Per l'unione degli angoli si consiglia l'utilizzo del collante

Squadretta a pulsante  
Ra 1048

Lavorazioni Processing

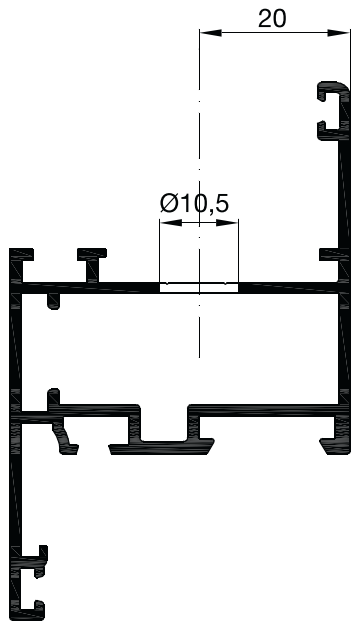

TR 4701

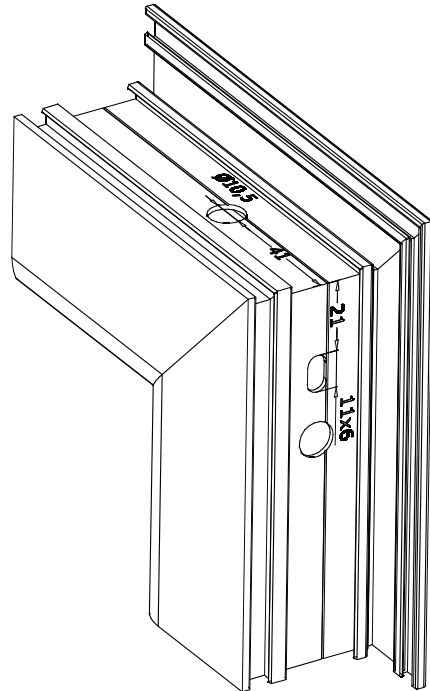

N.B. - Lavorazione eseguita con punzonatrice Ra 3800  
- Per l'unione degli angoli si consiglia l'utilizzo del collante

Squadretta di allineamento Ra 1704

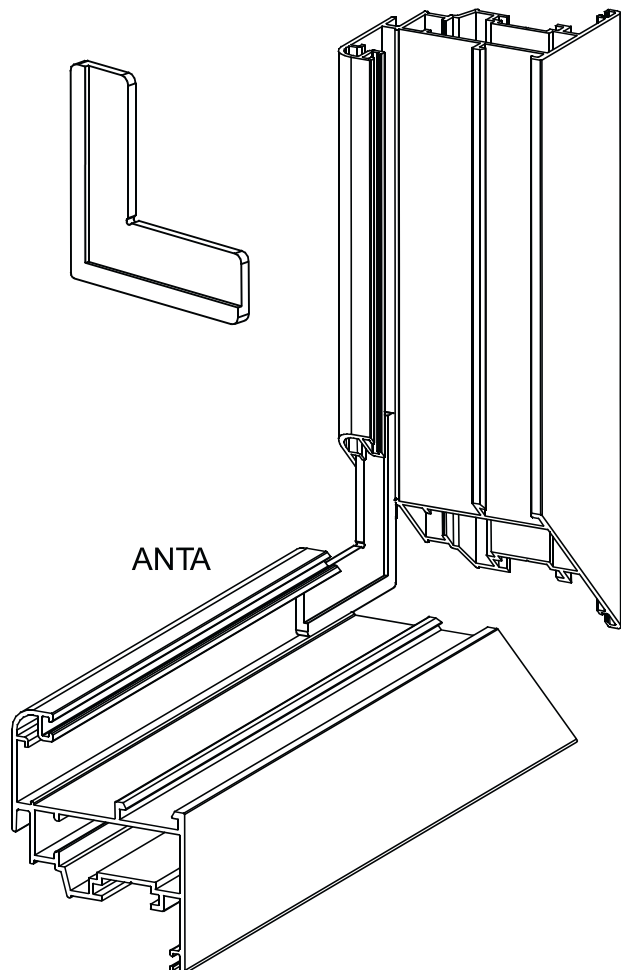
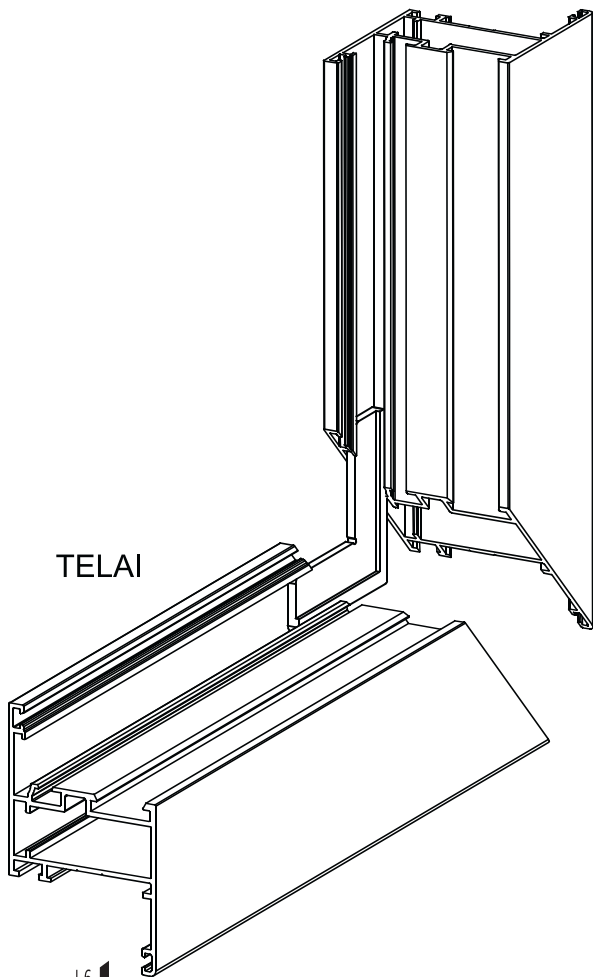

ANTE

FERMAVETRI DRITTI

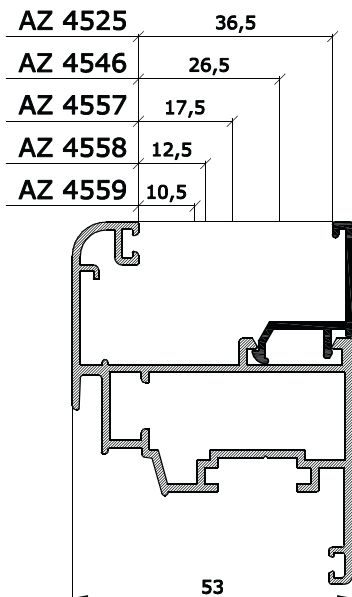

FERMAVETRI ARROTONDATI

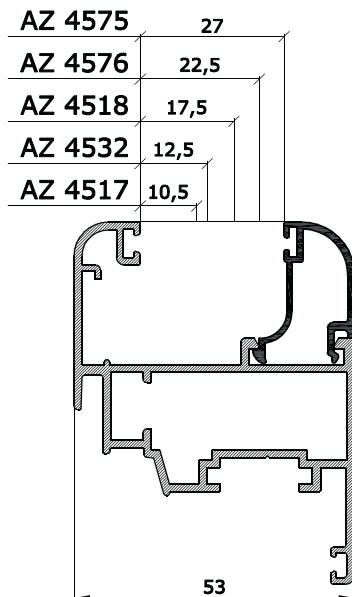

FERMAVETRI SCORNICIATI

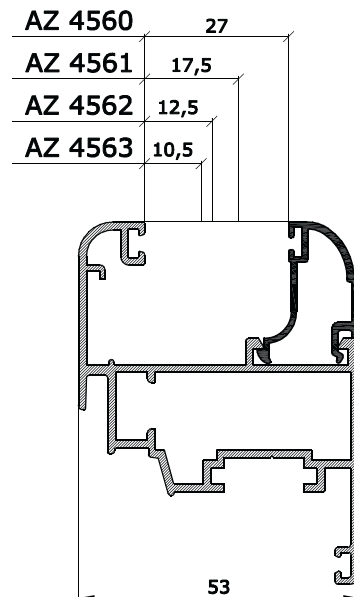

TELAI

FERMAVETRI DRITTI

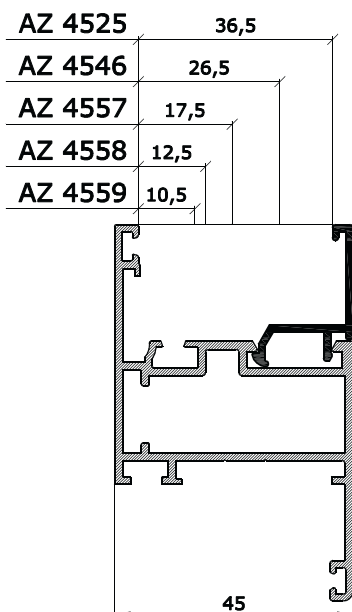

FERMAVETRI ARROTONDATI

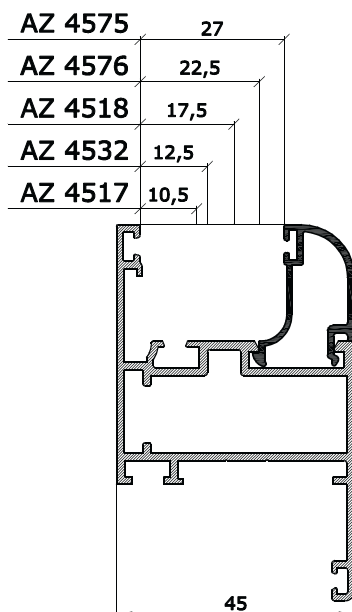

FERMAVETRI SCORNICIATI



TABELLA GUARNIZIONI  
(QUOTE CON GUARNIZIONI IN OPERA)

Rg 30 7 2 mm.	Rg 320 3 mm.	Rg 308 4 mm.	Rg 321 5 mm.	Rg 309 6 mm.	Rg 350 2,5 mm.	Rg 351 3,5 mm.	Rg 360 5 mm.



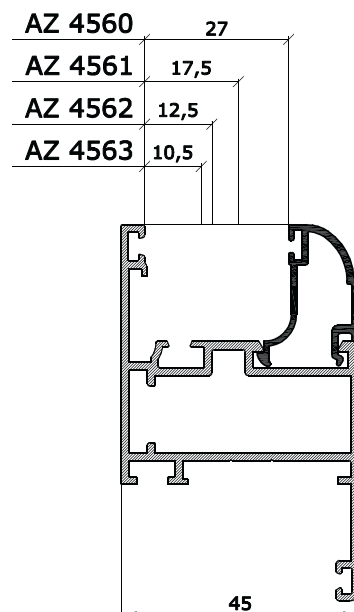
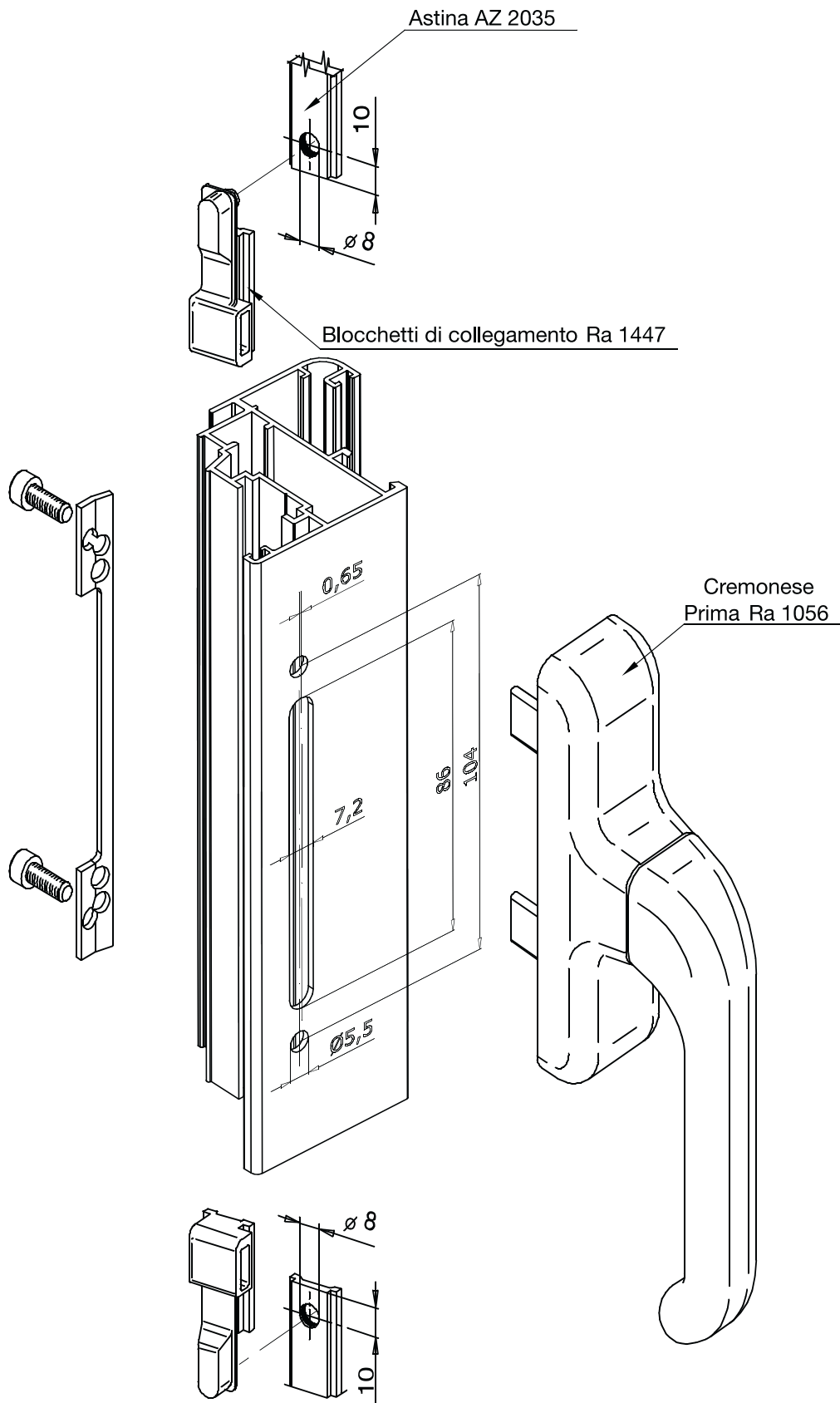

Lavorazioni Processing

Perno Ra 1446

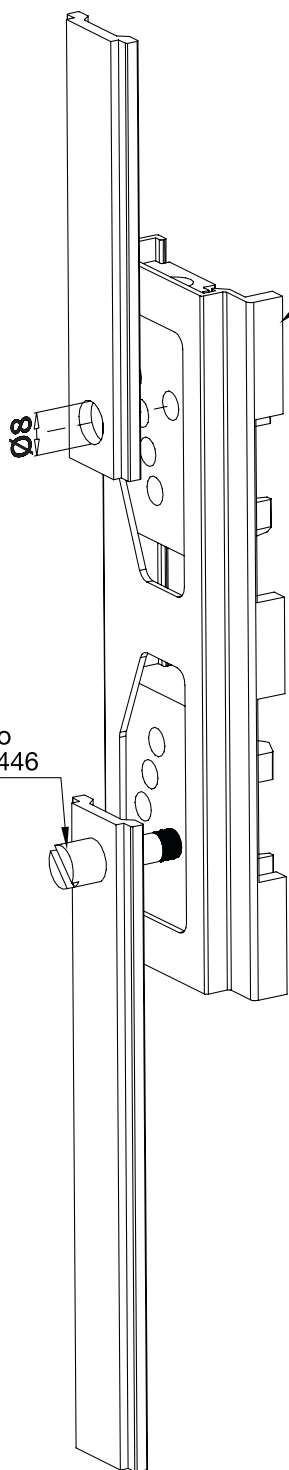

Kit per apertura esterna Ra 1029

Posizione Perno	Quota X
A	10 mm
B	24,5 mm
C	46,5 mm
D	52,5 mm
E	38,5 mm

- C 21
- A 26
- B 28
- E 30
- D 33

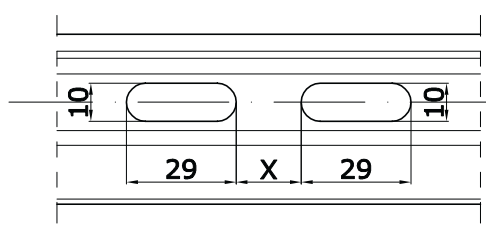
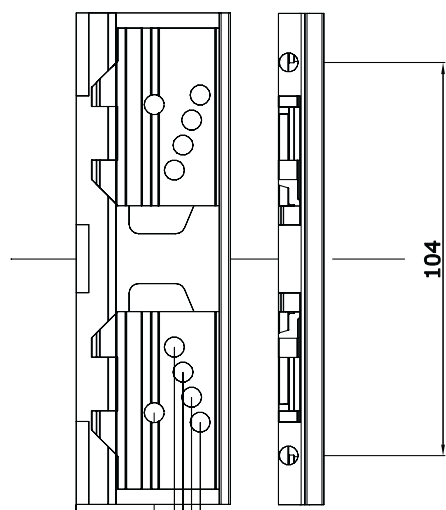
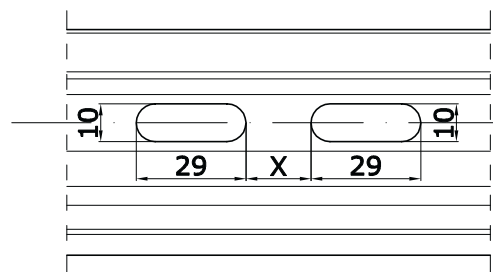

TR 4724

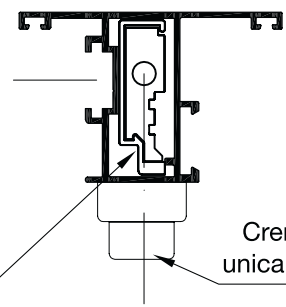

Cremonese unica Ra 1031

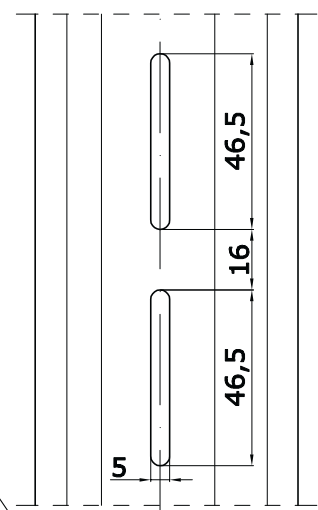

Cremonese unica Ra 1031

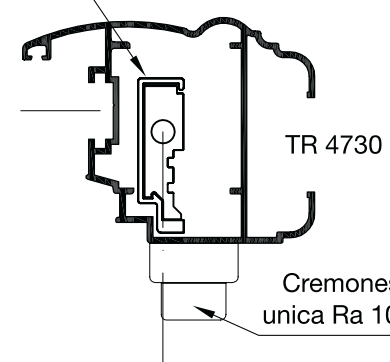

TR 4730

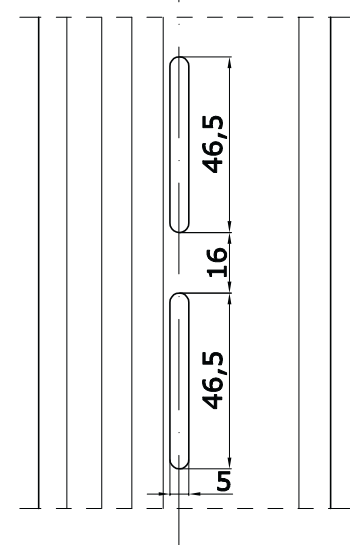

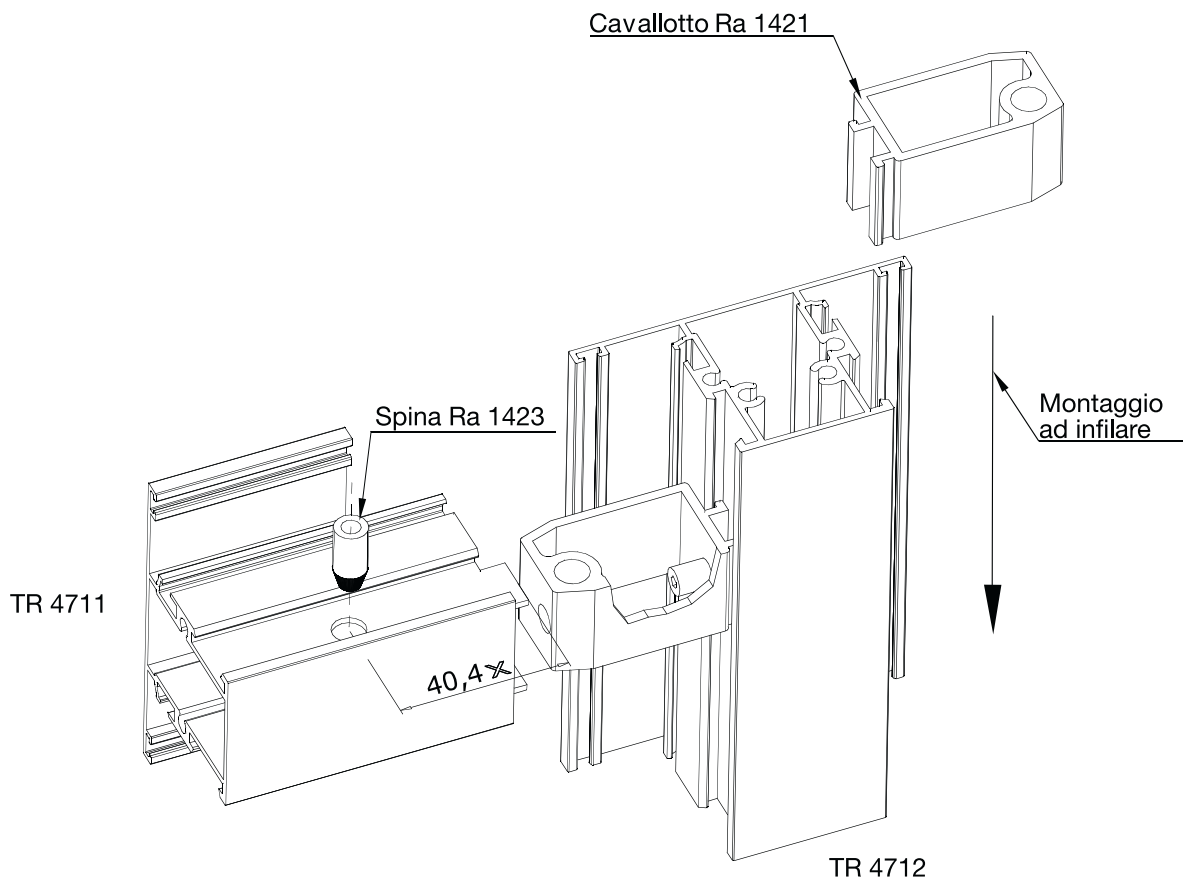
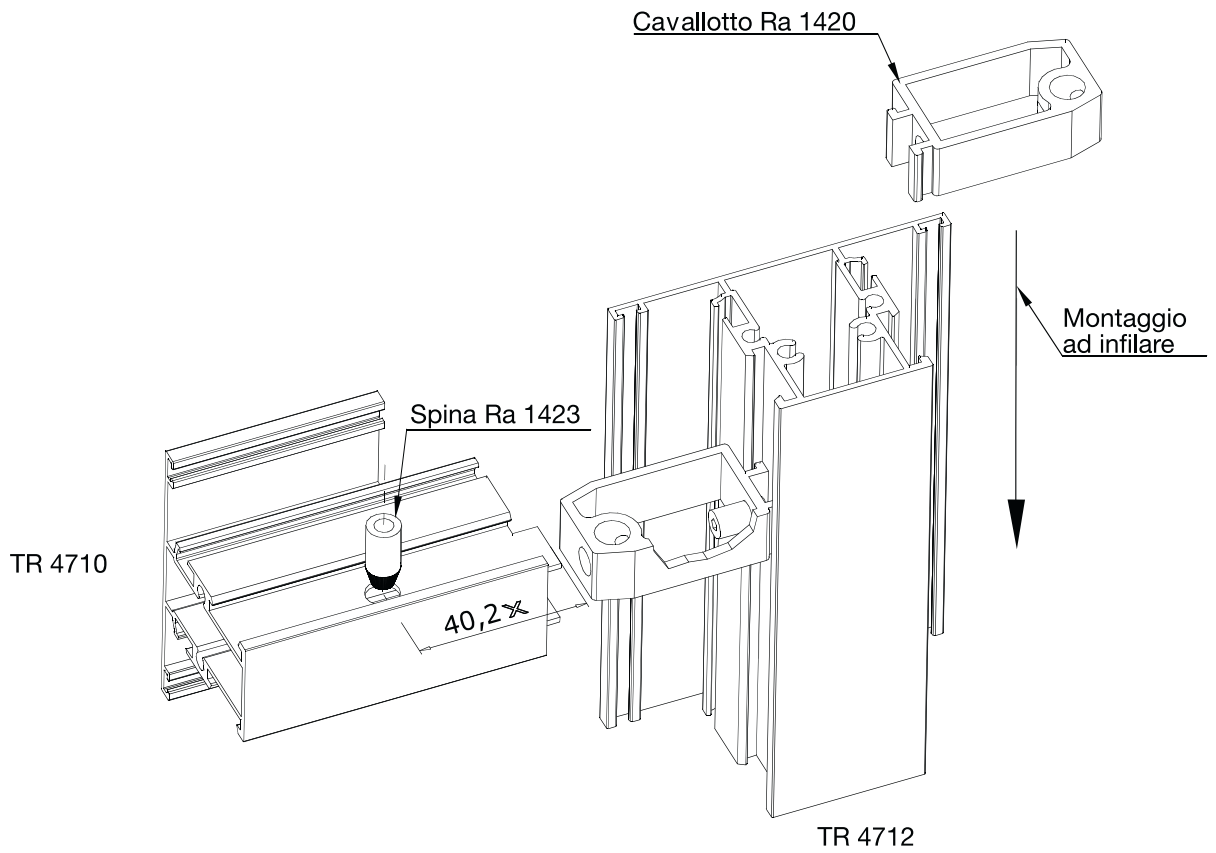

✘ da verificare in fase di lavorazione

N.B. - Lavorazione eseguita con gruppo fresa Ra 3801  
- Per l'unione degli angoli si consiglia l'utilizzo del collante

Lavorazioni Processing

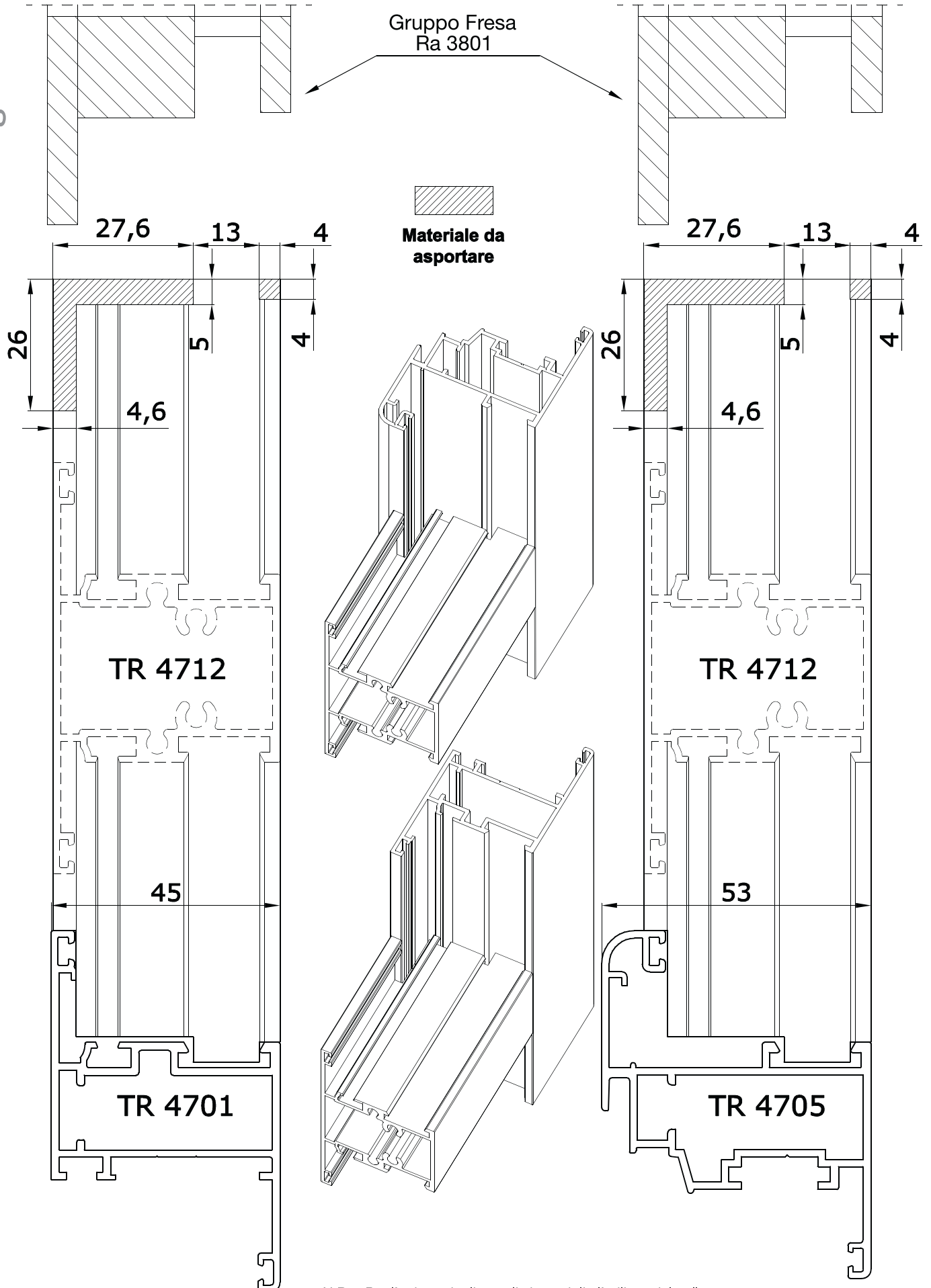

N.B. - Per l'unione degli angoli si consiglia l'utilizzo del collante  
 - Stessa lavorazione sui profili: TR 4710, TR 4711, TR 4713,  
 TR 4714, TR 4715, TR 4716, TR 4754, TR 4770

Lavorazioni Processing

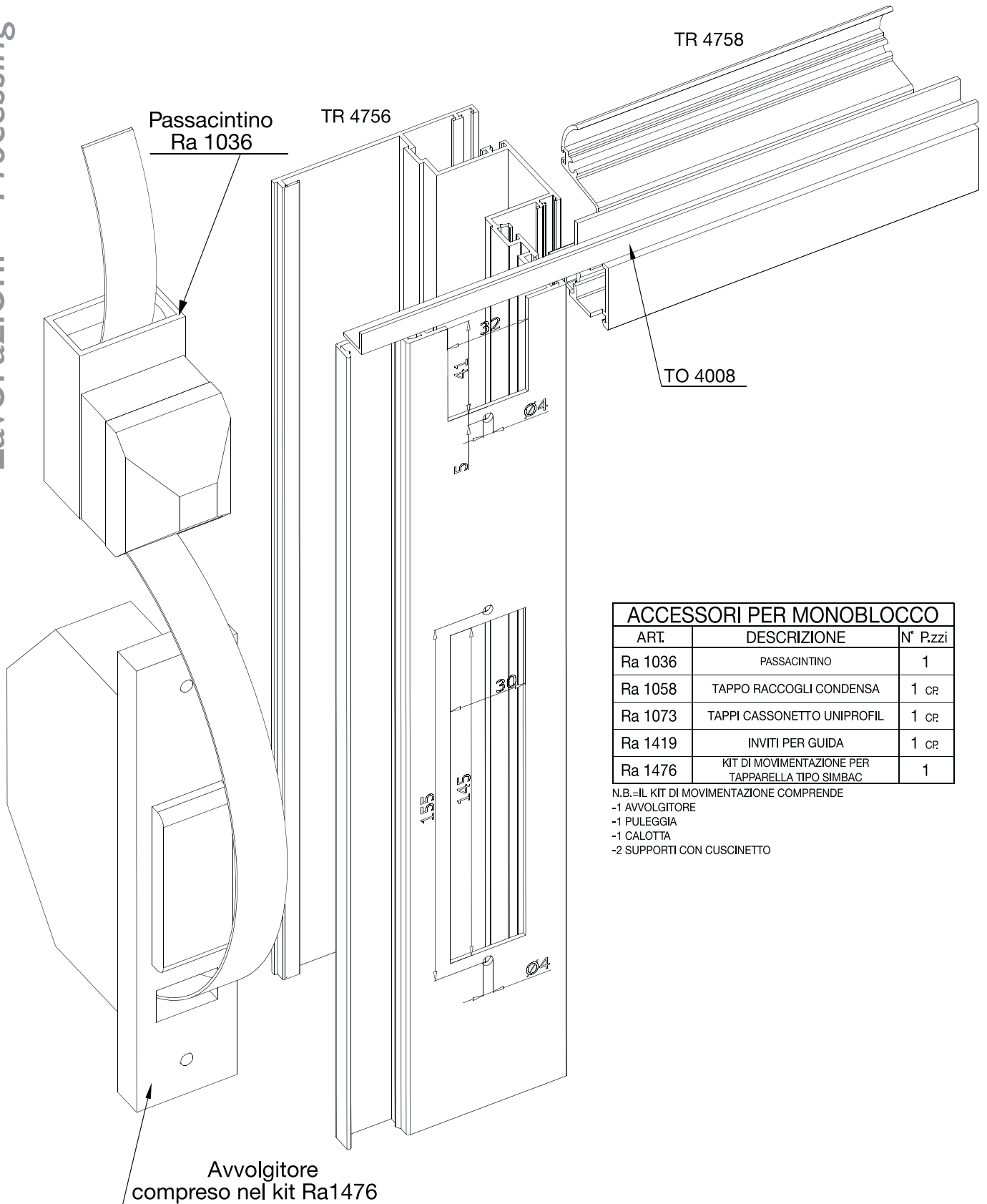

ACCESSORI PER MONOBLOCCO		
ART.	DESCRIZIONE	N° P.zzi
Ra 1036	PASSACINTINO	1
Ra 1058	TAPPO RACCOGLI CONDENSA	1 CP
Ra 1073	TAPPI CASSONETTO UNIPROFIL	1 CP
Ra 1419	INVITI PER GUIDA	1 CP
Ra 1476	KIT DI MOVIMENTAZIONE PER TAPPARELLA TIPO SIMBAC	1

N.B.=IL KIT DI MOVIMENTAZIONE COMPRENDE  
 -1 AVVOLGITORE  
 -1 PULEGGIA  
 -1 CALOTTA  
 -2 SUPPORTI CON CUSCINETTO

Lavorazioni Processing

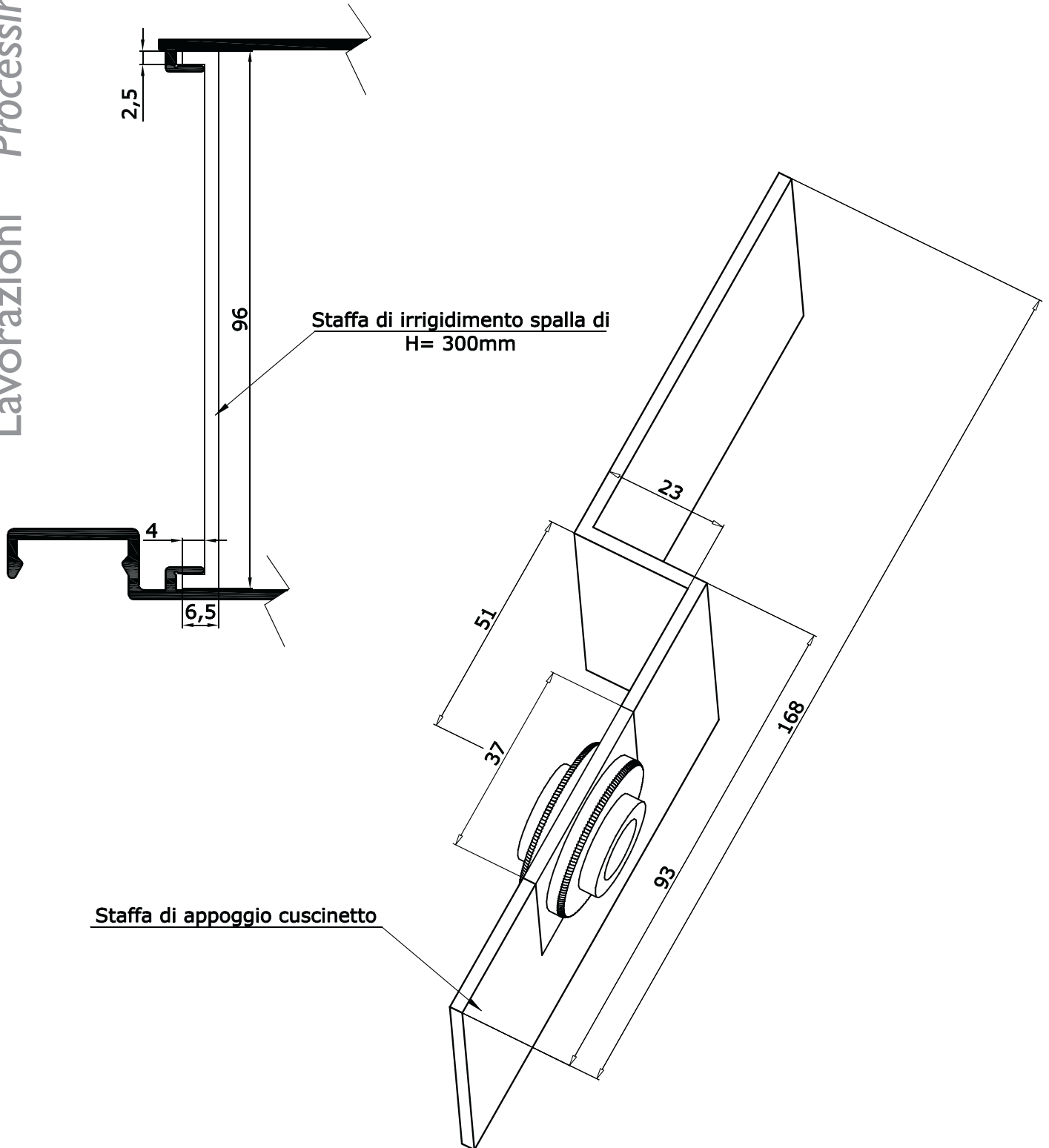

Lavorazioni Processing

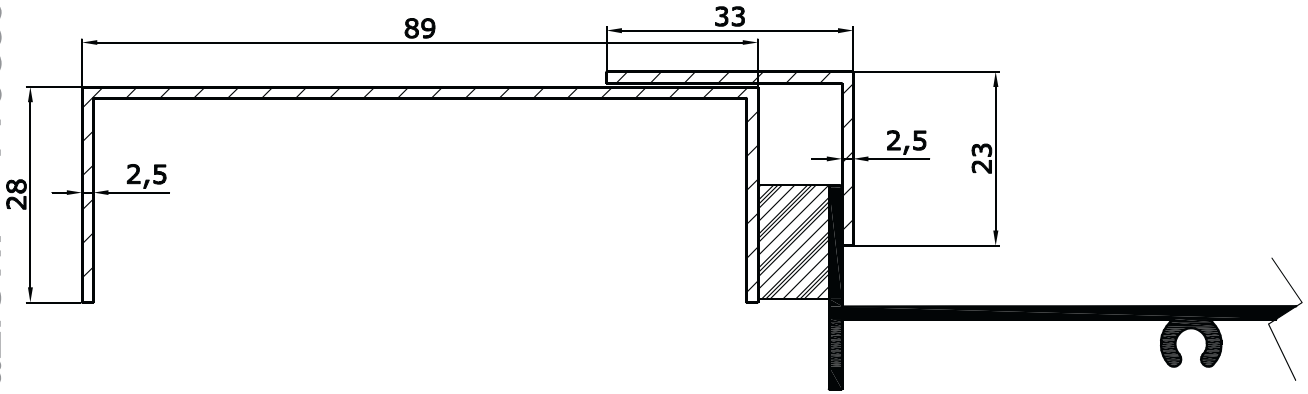

Angolare di fissaggio  
cassonetto

Controtelaio per  
monoblocco trasverso

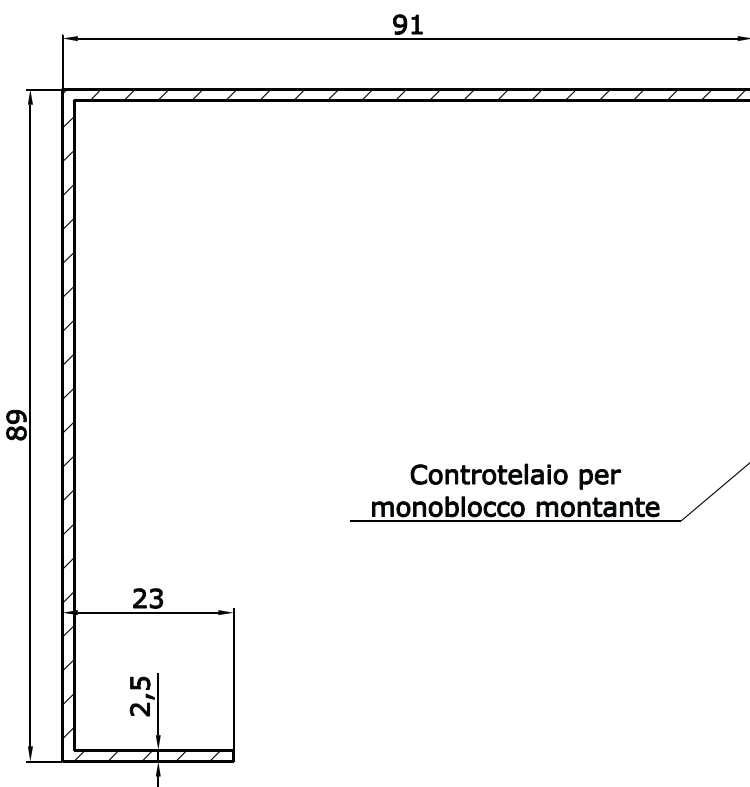

Controtelaio per  
monoblocco montante

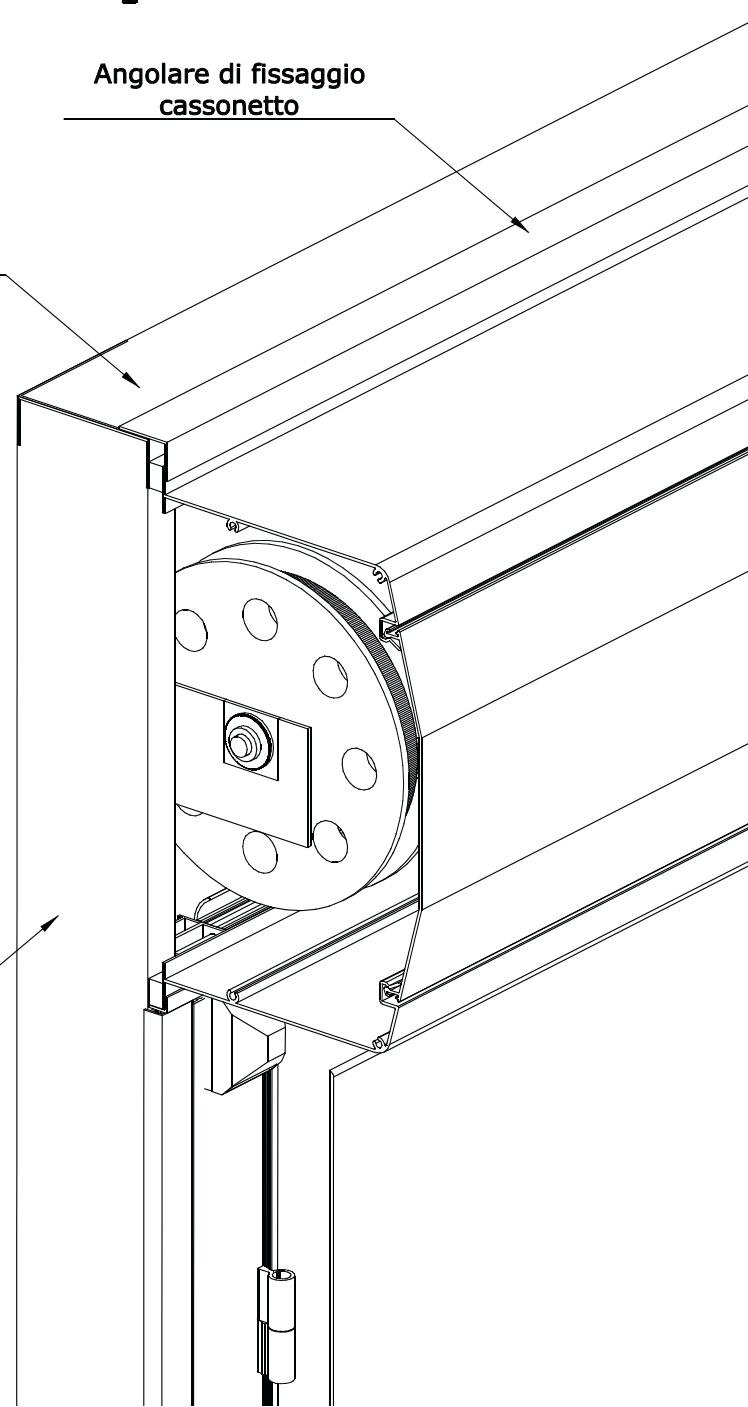

Lavorazioni Processing

